



Arnold Schwarzenegger
Governor

Cost-effective Demand Response Market Analysis and Product Specification Report



Prepared For:
California Energy Commission
Public Interest Energy Research Program

Managed By:
Architectural Energy Corporation
Prepared By:
NEV Electronics LLC

PIER PROJECT REPORT

November 2007

CEC-500-06-035



Managed By:
Architectural Energy Corporation
Judie Porter
Boulder, Colorado 80301
Commission Contract No. 500-06-035

Prepared By:
NEV Electronics LLC
Joel Snook
Grass Valley, CA 95945

Prepared For:
Public Interest Energy Research (PIER) Program
California Energy Commission

Michael Seaman
Contract Manager

Norm Bourassa
Program Area Lead
PIER Buildings End-Use Energy Efficiency Program

Daryl Mills
Office Manager
PIER Buildings End-Use Energy Efficiency Program

Martha Krebs
Deputy Director
ENERGY RESEARCH & DEVELOPMENT DIVISION

B.B. Blevins
Executive Director

DISCLAIMER

This report was prepared as the result of work sponsored by the California Energy Commission. It does not necessarily represent the views of the Energy Commission, its employees or the State of California. The Energy Commission, the State of California, its employees, contractors and subcontractors make no warrant, express or implied, and assume no legal liability for the information in this report; nor does any party represent that the uses of this information will not infringe upon privately owned rights. This report has not been approved or disapproved by the California Energy Commission nor has the California Energy Commission passed upon the accuracy or adequacy of the information in this report.

Acknowledgements

The project team acknowledges the support of the California Energy Commission PIER program and others in the lighting research community that directly or indirectly contributed to the information in this report. Additionally, the team appreciates the information provided by ADM Associates.

Preface

The Public Interest Energy Research (PIER) Program supports public interest energy research and development that will help improve the quality of life in California by bringing environmentally safe, affordable, and reliable energy services and products to the marketplace.

The PIER Program, managed by the California Energy Commission (Energy Commission), conducts public interest research, development, and demonstration (RD&D) projects to benefit California.

The PIER Program strives to conduct the most promising public interest energy research by partnering with RD&D entities, including individuals, businesses, utilities, and public or private research institutions.

PIER funding efforts are focused on the following RD&D program areas:

- Buildings End-Use Energy Efficiency
- Energy Innovations Small Grants
- Energy-Related Environmental Research
- Energy Systems Integration
- Environmentally Preferred Advanced Generation
- Industrial/Agricultural/Water End-Use Energy Efficiency
- Renewable Energy Technologies
- Transportation

Cost-effective Demand Response Market Analysis and Product Specification is the interim report for Project 3: Cost-effective Demand Response conducted by NEV Electronics LLC under the Lighting California's Future Program (contract number 500-06-035) that is managed by Architectural Energy Corporation. The information from this project contributes to PIER's Buildings End-Use Energy Efficiency Program.

For more information about the PIER Program, please visit the Energy Commission's website at www.energy.ca.gov/pier or contact the Energy Commission at 916-654-5164.

Table of Contents

Acknowledgements	iii
Preface	iv
Abstract	vi
1.0 Executive Summary	1
2.0 Introduction.....	1
3.0 CEDR Product Overview	2
4.0 Prior Market Studies	3
4.1. Target Markets.....	3
4.2. Bi-level Switching Characterizations.....	7
5.0 Utility Demand Price Structures	11
6.0 Initial Product Specification.....	11
6.1. Target price points for control and receiver devices.....	11
6.2. Target installation labor costs for installation of control and receiver devices	12
6.3. Minimum lighting loads needed to achieve an acceptable payback	12
6.4. Demonstration Site Criteria	12
6.5. Product Offering Recommendations.....	13
7.0 Appendix A – Initial CEDR Economics.....	14

Abstract

Lighting California's Future (LCF) is a \$3.7 million California Energy Commission Public Interest Energy Research Program focused on lighting technologies for buildings. The project on Cost-Effective Demand Response seeks to introduce a novel demand response lighting control technology that can be easily retrofit to existing buildings. The new system will be capable of receiving a utility demand reduction signal and transmitting, over the building power lines, a load-shed signal to multiple receiver devices.

This report provides a market assessment reviewing previous studies, which suggest that CEDR should focus on commercial private and open office applications. The report also provides an initial product specification.

1.0 Executive Summary

Lighting California's Future (LCF) is a \$3.7 million California Energy Commission Public Interest Energy Research Program focused on lighting technologies for buildings. The project on Cost-Effective Demand Response (CEDR) seeks to introduce a novel demand response lighting control technology that can be easily retrofit to existing buildings. The new system will be capable of receiving a utility demand reduction signal and transmitting, over the building power lines, a load-shed signal to multiple receiver devices. Proof of concept prototypes have been built and are being tested.

Market studies suggest that CEDR should focus on commercial private and open office applications. The installed cost is anticipated to be low enough to have less than a three-year payback period taking advantage of existing utility demand response incentive programs when applied sensibly. The CEDR product can interface to any system for sending the demand response (DR) signal from the utilities to the building's load centers at an additional cost that must be supported by sufficient CEDR-controlled loads.

2.0 Introduction

LCF is a \$3.7 million California Energy Commission Public Interest Energy Research Program focused on lighting technologies for buildings. The program, which is managed by Architectural Energy Corporation, features nine technical projects and a cross-cutting market connection project. LCF will help meet California's growing needs for energy efficiency and demand response with the goal of creating energy-efficient, advanced lighting technologies, products, systems, and implementation tools and bringing them to the market for the benefit of California citizens.

The CEDR project seeks to introduce a novel DR lighting control technology that can be easily retrofit to existing buildings. This project will develop a new system capable of receiving a utility demand reduction signal and transmitting, over the building power lines, a load-shed signal to multiple receiver devices. The outcome of the project is the development and commercialization of a novel demand responsive lighting technology. CEDR takes a low-tech approach, doing only one simple task inexpensively – reducing loads during DR conditions. Key project members are the California Lighting Technology Center (CLTC), NEV Electronics LLC, and Southern California Edison (SCE).

This report provides a market assessment reviewing previous studies about energy use in California by market sector, bi-level switching conditions, and demand response (DR) savings potential. It also estimates anticipated labor and installation costs, and proposes market penetration scenarios to help establish and refine target system price points.

The key sections of this report are: product overview, prior market studies, utility demand price structure, and initial product specification. The report also serves the function of providing information needed to transfer the technology into the market place.

3.0 CEDR Product Overview

The CEDR product solves the problem of shedding loads in response to a DR signal delivered to a building’s load center, making use of the existing power wiring (see Figure 1). The most cost effective targets are likely to be retrofits controlling bi-level switched lighting. Proof of concept prototypes have been built and are being tested at the CLTC.

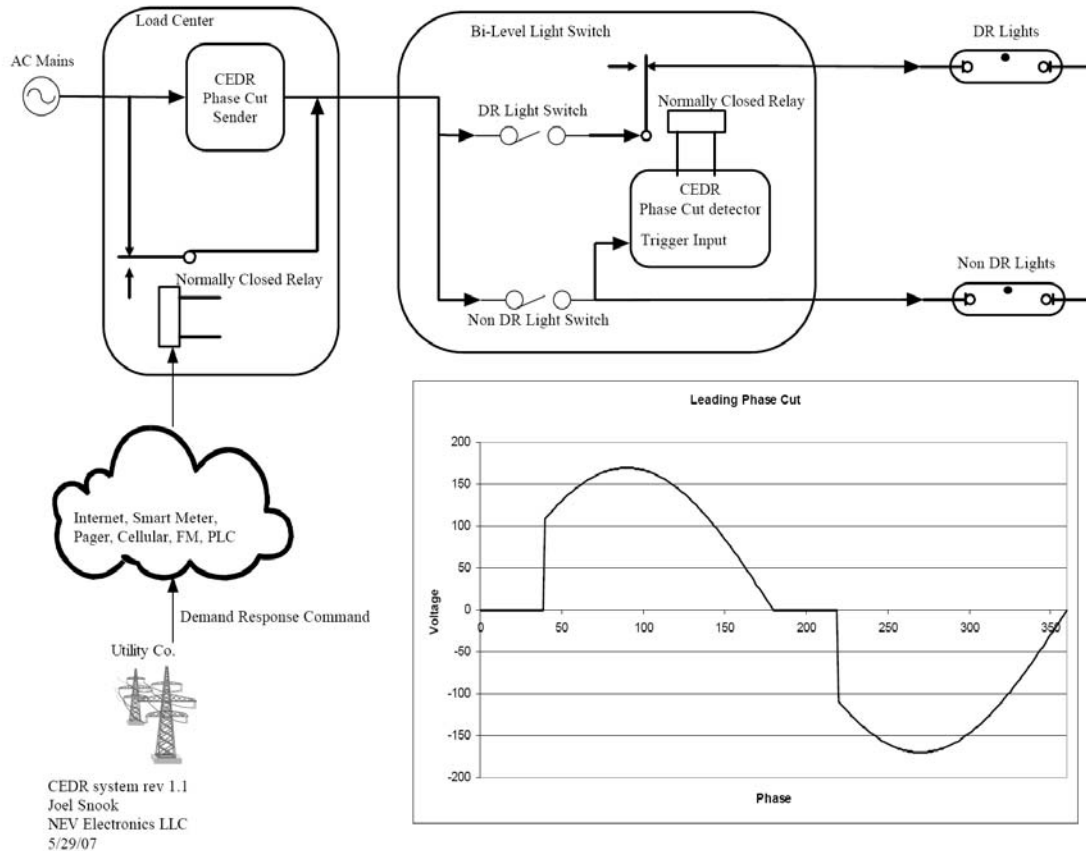
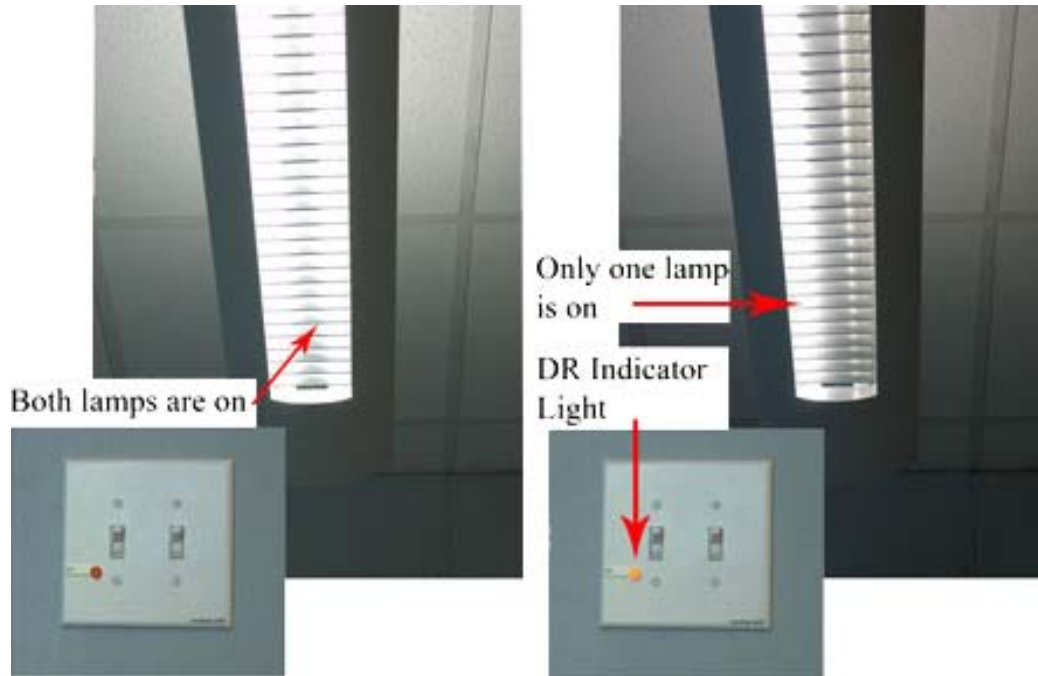

Figure 1: Block diagram of the CEDR

Once receiving the test load-shed signal, the CEDR system switches the attached bi-level lighting system from 100 percent down to 50 percent. If the lighting was already manually turned off or down to 50 percent by the occupant, the CEDR system prevents the user from returning the lighting to 100 percent until the load-shed signal is removed. The photographs below show the CEDR system installed on a lighting circuit. The switch includes a DR indicator light.



The prototype display at the CLTC includes both standard receptacles and “DR-override” receptacles. Equipment plugged into the standard receptacles are unaffected by CEDR during load-shed events, while equipment plugged into the DR-override receptacles are switched off. A DR-indicator lights up at the DR-override receptacles during DR events so that occupants can see that CEDR has turned off the controlled receptacles.

Field test studies are planned as part of this PIER LCF project. The system is patent-pending and available for licensing by a manufacturer.

4.0 Prior Market Studies

The project team reviewed literature about energy and peak demand users and bi-level switching applications/characteristics in California. The studies included a body of reports from Lawrence Berkeley National Laboratory (LBNL)¹ and Heschong Mahone Group² (HMG) as well as other studies.

4.1. Target Markets

The research team reviewed numerous publications for information about peak demand use by market. The goal was to understand the best target market.

1 <http://drcc.lbl.gov/pubs/62226.pdf>

2 <http://www.h-m-g.com>

Figure 2, from a report³ by the CALMAC (California Measurement Advisory Council) organization, indicates that commercial customers are the largest market segment, representing 38 percent of the total state peak energy demand. Figure 3, from the same report, shows the lighting contribution from the commercial sector for peak demand is 33 percent, only second to cooling use. The findings suggested that commercial end-users are a reasonable primary target market.

Figure 2
Contribution of Major IOU Commercial Sector to Peak Demand*

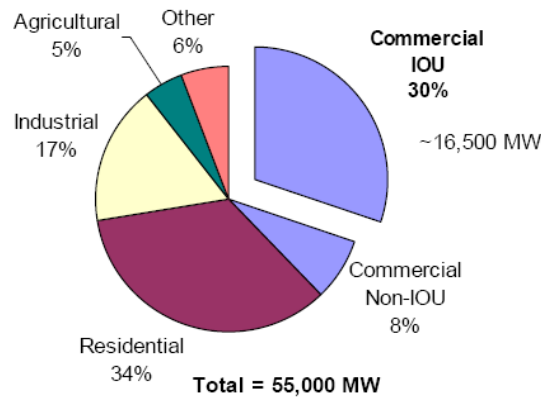
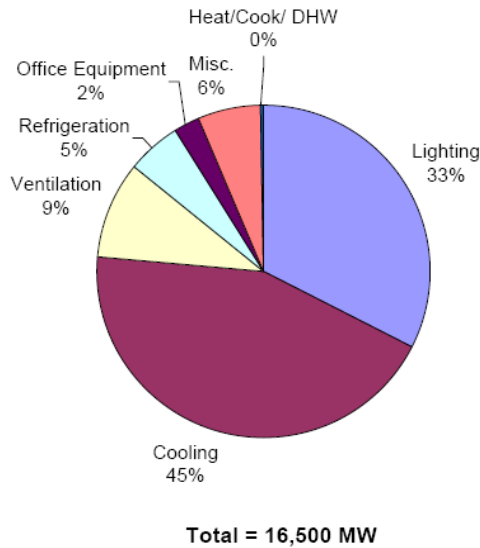

Figure 3
Breakdown of Commercial IOU Summer Peak Demand by End Use: 2000



³ http://www.calmac.org/publications/CA_EEPotV1.pdf

Also, the team found information¹ from LBNL (see Figure 4) that shows large offices are the biggest lighting energy users among commercial buildings. Thus, large offices seem to be a reasonable initial target for CEDR.

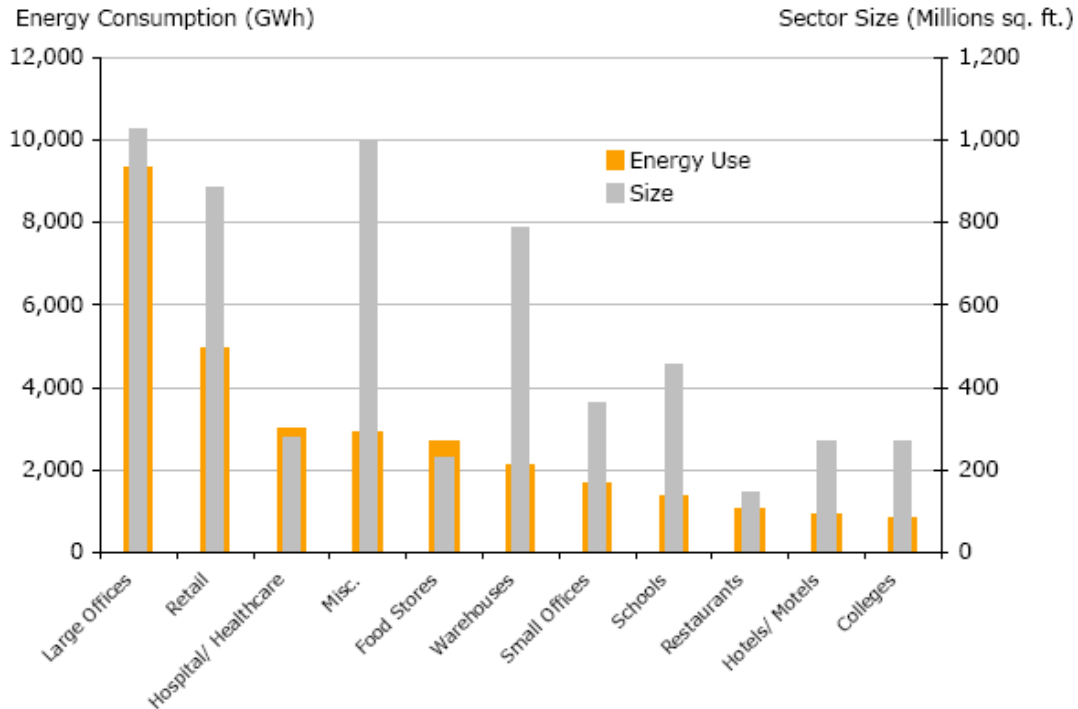

Figure 4: Lighting Energy Use for California Commercial Buildings in 2000

The 1999 *Lighting Efficiency Technology Report*⁴, authored by Heschong Mahone Group, shows (see Figure 5) that small and large office buildings together make up 22 percent of California's annual commercial lighting energy usage.

⁴ <http://www.h-m-g.com/downloads/LET/VOLUME01.PDF>

**Percentage of Statewide Lighting Energy Use,
by Building Type, by Lamp Type**

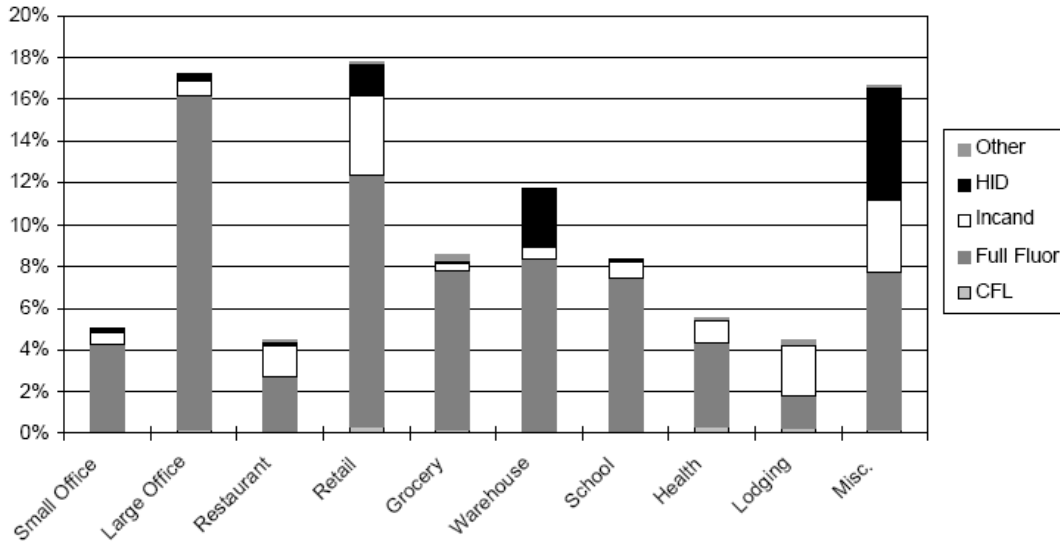

Figure 5: Commercial Lighting Energy Use, by Building and Lamp Type

*Lighting Controls Effectiveness Assessment*⁵, prepared by ADM Associates Inc., reports the annual energy usage of newly constructed open offices and private offices in Table 1. Using the information in this table, one could calculate that 75 percent of the office building lighting energy usage is attributable to open offices and 25 percent to private offices.

Table 1: *Estimated Aggregate Annual Electric Savings from Use of Bi-Level Switching in Different Types of Spaces in Newly Constructed Buildings (Usage and Savings in million kWh)*

<i>Type of Space</i>	<i>Estimated Annual Usage</i>	<i>Estimated Annual Savings</i>	<i>Annual Usage + Annual Savings</i>	<i>Percent Savings</i>
Open office	291,981	55,561	347,541	16.0%
Private office	97,486	26,817	124,303	21.6%
Retail	839,398	146,047	985,445	14.8%
Classroom	75,297	6,837	82,134	8.3%

⁵ Lighting Controls Effectiveness Assessment, Final Report on Bi-Level Lighting Study, May 2002, Prepared by ADM Associates Inc. for Heschong Mahone Group under the California Statewide MA&E Program on behalf of Southern California Edison and the California Energy Commission.

Based on the afore-mentioned information, the team believes commercial lighting, specifically office buildings, is the best match for CEDR and did not pursue quantifying the remaining lighting potential for other building types at this time. Large open offices in other building types (e.g. healthcare, schools) are also a good target for CEDR, but data currently is not available to quantify other markets. Additionally, it seems intuitive to assume that the residential market is not economically viable at this time.

4.2. Bi-level Switching Characterizations

Statewide load on bi-level switching characterizations were researched and the following information found.

- Peak demand contribution from lighting in commercial buildings on a peak day in California in 2003 equaled 6 Giga Watts (GW).
- 75 percent of commercial lighting load is bi-level switched.
- Seven percent of commercial lighting load is controlled by advanced lighting controls.
- Lighting controlled by advanced lighting controls may not require CEDR to have DR ability.

The most conservative calculation is to assume that all lighting controlled by advanced lighting controls is also controlled by bi-level switching. Thus, the following is calculated:

- $75 \text{ percent} - (7 \times 75 \text{ percent}) = 70 \text{ percent}$ of commercial lighting in California can use CEDR.
- $70 \text{ percent} \times 6\text{GW} = 4.2\text{GW}$ is the state wide load on bi-level switches. This is the actual load, not the maximum possible load.

The team did not find data appropriate for creating a histogram of typical bi-level load profiles in buildings and occupancy usage patterns. However, the ADM report, which is based on monitoring 79 buildings and 256 spaces, presents an overall picture of usage for four space types. Table 2 on the next two pages shows the four graphs.

Table 2: Depicts bi-level switching states from four different space types. The graphs are taken directly from the ADM report.³

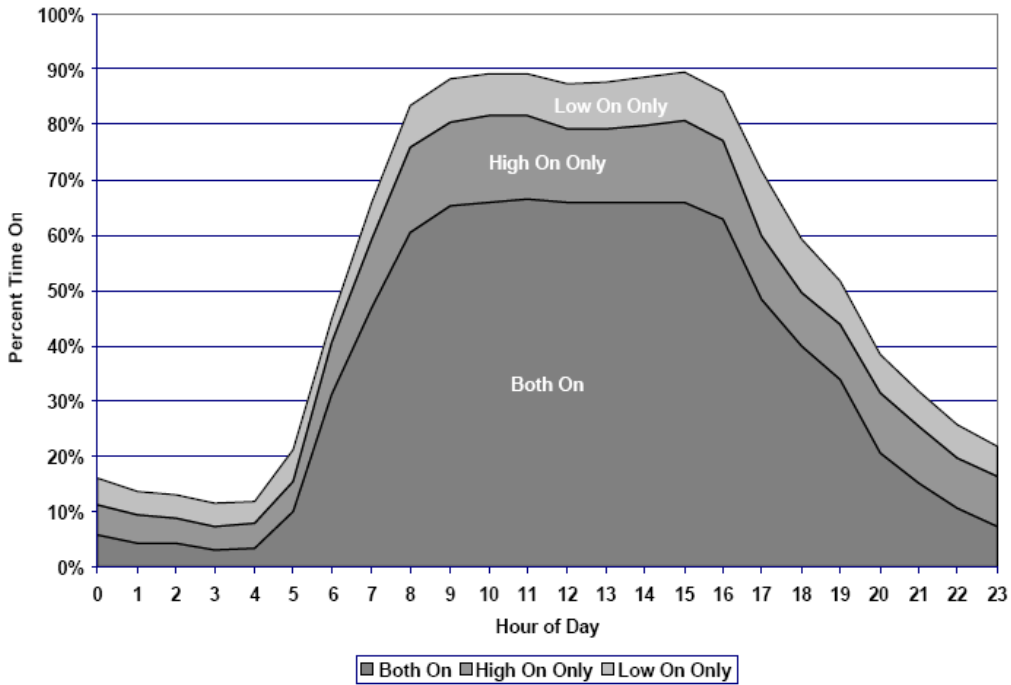

Percent of Time Bi-Level Switches in Open Office Areas are in Different States throughout a Weekday

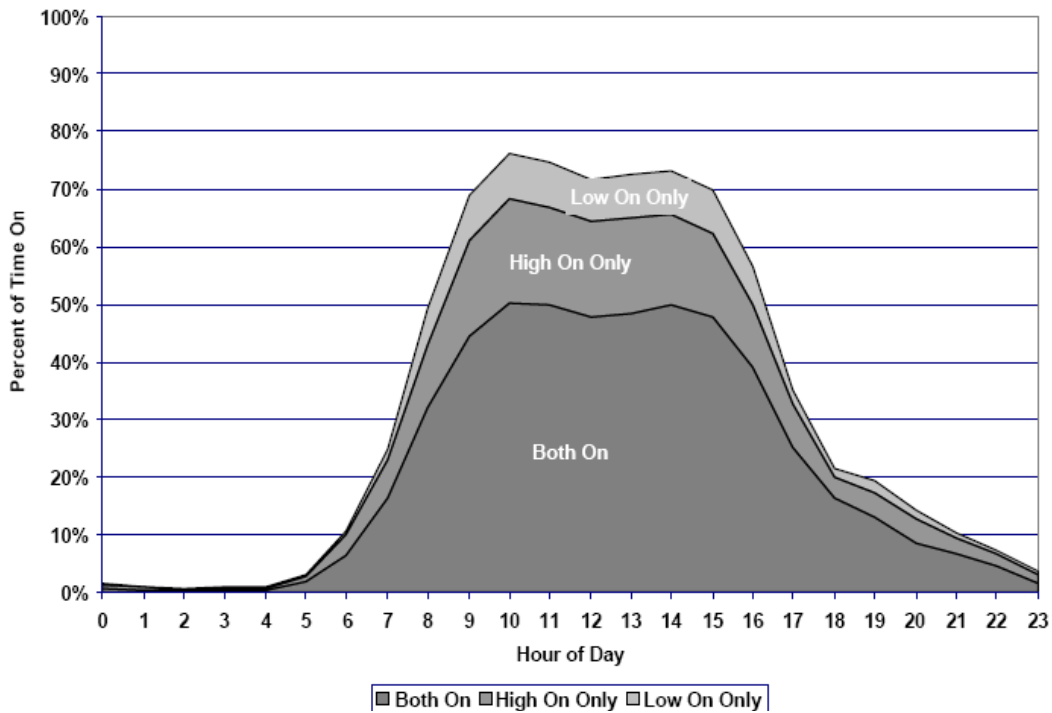

Percent of Time Bi-Level Switches in Private Office Areas are in Different States throughout a Weekday

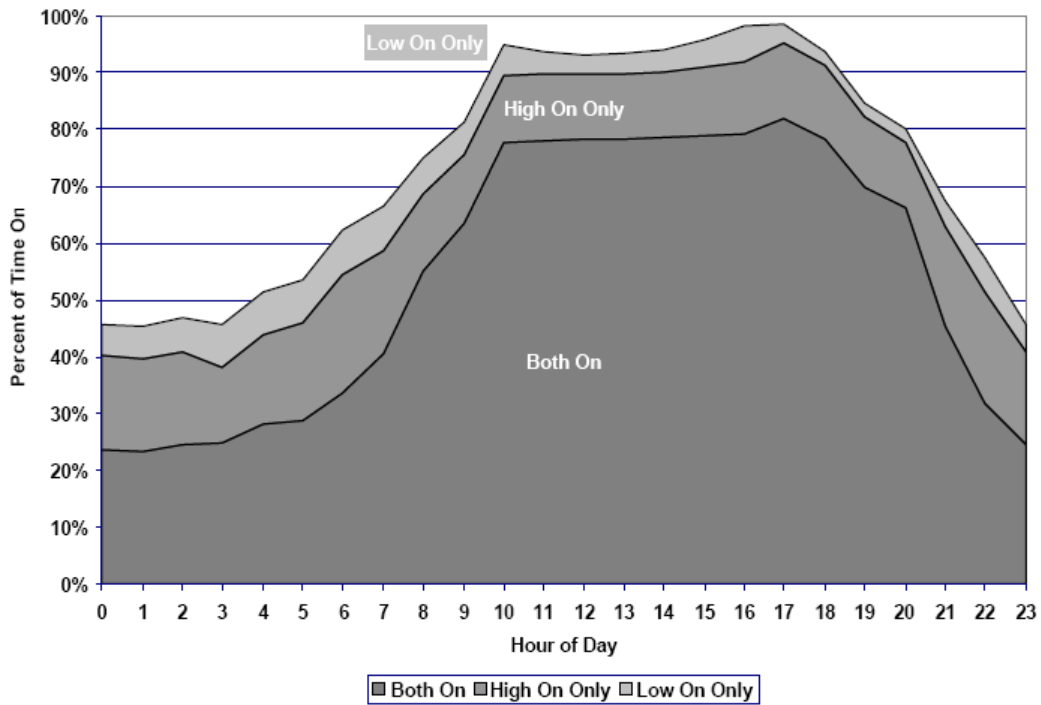

Percent of Time Bi-Level Switches in Retail Areas are in Different States throughout a Weekday

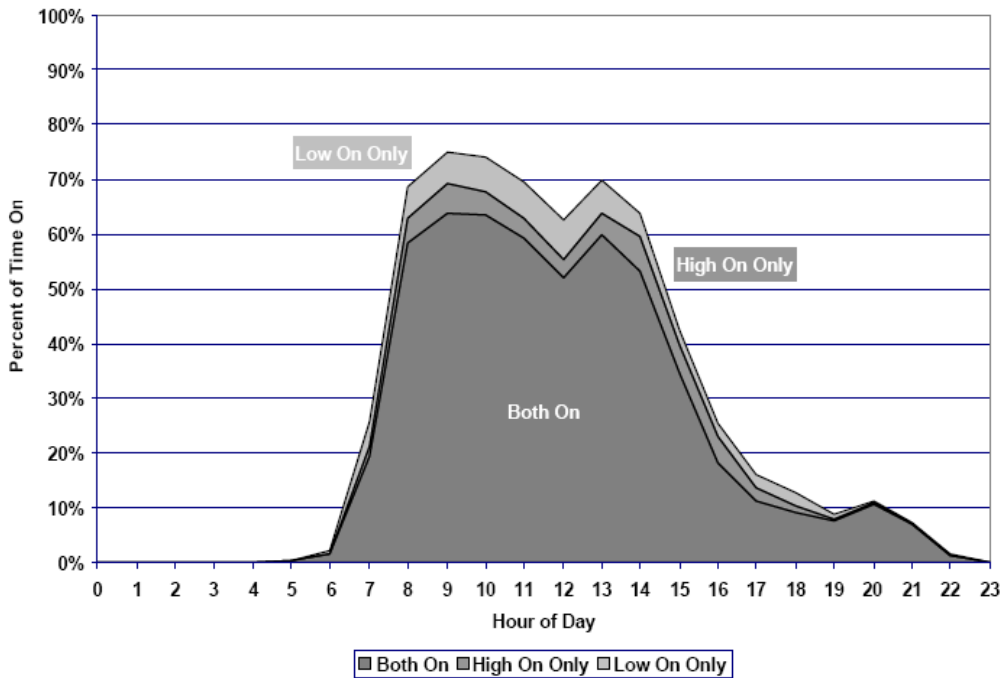

Percent of Time Bi-Level Switches in Classrooms are in Different States throughout a Weekday

Based on the ADM report, the estimated annual energy savings using bi-level switching in the different conditions are 16 percent for open offices, 21.6 percent for private offices, 14.8 percent for retail spaces, and 8.3 percent for classrooms (as shown in Table 1). If the open and private offices are aggregated, then the annual energy savings is almost 18 percent. It is reported in kWh savings, not demand savings. Finally, Table 3, also taken from the ADM report, indicates the breakdown of bi-level switching conditions for the four spaces.

Table 3. Percentage breakdown for bi-level switching for four different space types at 3 p.m. on weekdays.

<i>Type of Space</i>	<i>Both Switches Off</i>	<i>Both Switches On</i>	<i>High Wattage Switch Only On</i>	<i>Low Wattage Switch Only On</i>
Open office	10.4%	65.8%	14.9%	8.9%
Private office	30.3%	47.9%	14.5%	7.3%
Retail	4.1%	78.9%	12.0%	5.0%
Classroom	57.6%	34.4%	5.3%	2.8%

Based on the review of the bi-level switching characteristics data, the decision to focus specifically on office applications is reinforced and, again, seems to make the most economic sense.

Since office buildings use 22 percent of annual commercial lighting energy, that percentage is used as an approximation of the peak load percentage: 22 percent of 4.2GW = 920MW statewide load on bi-level switches for office buildings.

The research team makes the conservative assumption that the low power switch in the bi-level pair will be shed by CEDR. The *Lighting Controls Effectiveness Assessment*⁵ report uses a data set that provided insight into the percentage of the 4.2 GW that CEDR can shed by turning off the lower powered of the two bi-level switches. Because bi-level usage patterns and energy usage differ between open and private offices, two calculations are necessary.

- Open offices use 75 percent peak energy * (66 percent of bi-level switches are both on during peak times / 90 percent of bi-level switches at least one on during peak times) * 44 percent of load is controlled by the low switch = 220MW is the state wide load on the lower powered bi-level switches for open offices in office buildings.
- Private offices use 25 percent peak energy * (48 percent of bi-level switches are both on during peak times / 70 percent of bi-level switches at least one on during peak times) * 44 percent of load is controlled by the low switch = 69MW is the state wide load on the lower powered bi-level switches for private offices in office buildings.

Adding both together, the CEDR shed potential for bi-level switched lighting in California office buildings is estimated to be 290MW.

The required data to calculate the commercial non-office building bi-level switched cases currently is not available. To see if those cases are of interest, the team uses the private office statistics for calculations: (4,185MW total – 921MW office buildings) * 69 percent both switches on * 44 percent low switch = 980MW. This approximation shows CEDR should eventually pursue applications beyond commercial office buildings.

5.0 Utility Demand Price Structures

The project team reviewed the demand price structure⁶ for California utilities in order to quantify the value of removing load from the utility grid during peak demand periods. Pacific Gas & Electric Company (PG&E), SCE, and Sempra Utilities offer Base Interruptible Programs (BIP) which pay \$8 per sheddable kW per month, or \$96 per sheddable kW per year. Under BIPs, customers must commit to curtail at least 15 percent of average monthly load or a minimum of 100 kW. A Technology Incentive Program (TIP) also provides a rebate for installing DR equipment: PG&E pays \$250 and SCE pays \$300 per sheddable kW.

For example, the value of an office building removing load from the SCE grid during peak demand periods is \$96 per year per sheddable kW plus \$300 per sheddable kW for the installation of equipment.

While there are numerous conditions that must be met to participate, these programs provide a good indicator of the value of removing load from the utility grid during peak demand periods. Also, the 100 kW requirement for BIPs is applicable to all sheddable load in a building, which could include lighting, and heating, ventilation, and air conditioning equipment.

6.0 Initial Product Specification

The initial product specification for the CEDR System, based on market data summarized in previous sections, is described below.

6.1. Target price points for control and receiver devices

It is assumed that a low cost method of delivering the utility DR signal to commercial buildings will be selected from the many suitable alternatives under consideration by the utilities. The cost of getting that signal from the building entry point to the lighting load center will be shared among all the lighting branches served by that load center. This cost may also be largely born by other DR friendly measures such as Smart Meters and other DR signal consumers such as thermostats. For these reasons, the costs associated with getting the DR signal to the load center are neglected for the time being.

⁶ http://www.fypower.org/flexalert/demand_resp_programs.html

Sales price estimates are based on a manufacturer selling through distribution channels with typical markups. The team believes the following prices can be achieved in high volume production. Therefore, price targets to the consumers are: controller \$155 and receiver \$20.

6.2. Target installation labor costs for installation of control and receiver devices

Ease of installation was a very high priority during CEDR's concept and initial design. Jim Benya, PE, estimates that each CEDR transmitter or receiver will require 15 minutes of installation time by an electrician. This is based on his experience installing lighting control systems. The team has estimated an electrician's charge of \$75 per hour. Therefore, the installation cost for either a controller or receiver device is \$18.75.

6.3. Minimum lighting loads needed to achieve an acceptable payback

Using BIP and TIP programs mentioned in the Utility Demand Price Structures section and assuming that a three-year simple payback is acceptable to building owners, the following is necessary.

Existing commercial open office building lighting system assumes two sets of bi-level switches per 16A maximum breaker. The team is trying to get data on typical number of switches per breaker.

- CEDR System cost goals are $\$155 + 18.75 + 2 \times (\$20 + 18.75) = \$251$.
 - Where \$155 is the controller
 - Where \$18.75 is the electrician's cost for installing the controller
 - Where the CEDR receiver (\$20) is installed on 2 sets of switches by an electrician (\$18.75)
- Returns for three years are $\$117 \text{ TIP} + 3 * 45 \text{ BIP} = \251 for an acceptable payback for a sheddable load per open office lighting circuit breaker of 634W.

Appendix A provides more information on the initial economics for CEDR.

6.4. Demonstration Site Criteria

The project team has set the following criteria that are required for up to two demonstration sites possibly in SCE's territory. The present CEDR receivers can only switch 10A maximum and the team can save time by not having to develop a 16A receiver for the time being.

The first criterion is a site with an open office, plug loads, and optional private offices.

Open office criteria are:

- Lights powered by 277V 16A lighting only branch loaded to capacity and controlled by one or more bi-level switches.
- Occupants usually have both bi-level switches on.

- Bi-level switching is arranged intelligently, so that a one-third or one-half reduction does not prevent the occupants from doing their jobs.
- The open office is not so well lit by daylight that the over head lights would not be missed.

Plug loads and / or small offices are:

- Enough plug loads (and optional small offices) that the team can use the rest of the 10 CEDR receivers specified by the test plan. Assuming only one light switch in the open office means a combination of 9 plug loads or small offices.
- Plug loads of 200W to 1kW per outlet that run continuously during the afternoon.
- The private office occupants usually have both bi-level switches on.
- The private office bi-level switching is arranged intelligently, so that a one-third or one-half reduction does not prevent the occupants from doing their jobs.
- The private office is not so well lit by daylight that the over head lights would not be missed.

6.5. Product Offering Recommendations

Moving forward, the project team will continue to narrow the CEDR initial product offering, focusing on the following.

- Identify specific commercial office building type – for example, owner-occupied versus tenant with more than 50 hours of lighting operation per week. Summer operation essential.
- Identify building size – for example, greater than 50,000 square feet office or possibly based on a minimum lighting power density, if it can be determined.
- Continue to evaluate optimal CEDR package – using feedback from demonstration sites, fine-tune cost and savings per installation, and better understand utility incentives and requirements.
- Develop marketing materials that clearly communicate ease of install and customer acceptance of dimming; communicate importance of seamlessly contributing to shedding load for the common good of California citizens.

Also, the project team is in discussion with a couple of potential manufacturers. These discussions will continue to proceed.

7.0 Appendix A – Initial CEDR Economics

Open office lighting circuit with T-24 switch(s) examples													
Mains voltage	kW total lighting load	% sheddable	kW sheddable	# T-24 switches (Two switch set)	kWatts Shed per switch	Installed cost	Allowed TIP Rebate	BIP / year	Simple Payback Years	3 year net	CEDR hardware cost / sheddable kW	CEDR installation cost / sheddable kW	
277	3.102	44%	1.365	2	0.683	\$251	\$251	\$131	0.00	\$393	\$142.85	\$41	
277	4.432	66%	2.925	2	1.463	\$251	\$251	\$281	0.00	\$842	\$66.66	\$19	
277	4.432	50%	2.216	2	1.108	\$251	\$251	\$213	0.00	\$638	\$88.00	\$25	
277	4.432	33%	1.463	2	0.731	\$251	\$251	\$140	0.00	\$421	\$133.33	\$38	
277	2.216	66%	1.463	2	0.731	\$251	\$251	\$140	0.00	\$421	\$133.33	\$38	
277	2.216	50%	1.108	2	0.554	\$251	\$251	\$106	0.00	\$319	\$175.99	\$51	
277	2.216	33%	0.731	2	0.366	\$251	\$251	\$70	0.97	\$142	\$266.66	\$77	
120	1.920	66%	1.267	2	0.634	\$251	\$251	\$122	0.00	\$365	\$153.88	\$44	
120	1.920	50%	0.960	2	0.480	\$251	\$251	\$92	0.12	\$265	\$203.13	\$59	
120	1.920	33%	0.634	2	0.317	\$251	\$251	\$61	1.53	\$90	\$307.77	\$89	
120	0.960	66%	0.634	2	0.317	\$251	\$251	\$61	1.53	\$90	\$307.77	\$89	
120	0.960	50%	0.480	2	0.240	\$251	\$251	\$46	2.85	\$7	\$406.25	\$117	
120	0.960	33%	0.317	2	0.158	\$251	\$79	\$30	5.66	-\$81	\$615.53	\$178	
Plug Load circuit examples													
Mains voltage	kW total lighting load	% sheddable	kW sheddable	# T-24 switches (Two switch set)	kWatts Shed per switch	Installed cost	Allowed TIP Rebate	BIP / year	Simple Payback Years	3 year net	CEDR hardware cost / sheddable kW	CEDR installation cost / sheddable kW	
120	1.920	100%	1.920	1	1.920	\$213	\$213	\$184	0.00	\$553	\$91.15	\$20	
120	1.920	50%	0.960	1	0.960	\$213	\$213	\$92	0.00	\$276	\$182.29	\$39	
120	1.920	25%	0.480	1	0.480	\$213	\$120	\$46	2.01	\$46	\$364.58	\$78	
120	1.920	10%	0.192	1	0.192	\$213	\$48	\$18	8.92	-\$109	\$911.46	\$195	
120	1.920	100%	1.920	4	0.480	\$329	\$329	\$184	0.00	\$553	\$122.40	\$49	
120	1.920	50%	0.960	4	0.240	\$329	\$240	\$92	0.96	\$188	\$244.79	\$98	
120	1.920	25%	0.480	4	0.120	\$329	\$120	\$46	4.53	-\$71	\$489.58	\$195	
120	1.920	10%	0.192	4	0.048	\$329	\$48	\$18	15.23	-\$225	\$1,223.96	\$488	
Small Office Lighting examples													
Based on assumption of 315W per office													
Mains voltage	kW total lighting load	% sheddable	kW sheddable	# T-24 switches (Two switch set)	kWatts Shed per switch	Installed cost	Allowed TIP Rebate	BIP / year	Simple Payback Years	3 year net	CEDR hardware cost / sheddable kW	CEDR installation cost / sheddable kW	
277	4.432	66%	2.925	14	0.209	\$716	\$716	\$281	0.00	\$842	\$148.71	\$96	
277	4.432	50%	2.216	14	0.158	\$716	\$554	\$213	0.76	\$476	\$196.30	\$127	
277	4.432	33%	1.463	14	0.104	\$716	\$366	\$140	2.50	\$71	\$297.42	\$192	
277	2.216	66%	1.463	7	0.209	\$445	\$366	\$140	0.57	\$342	\$201.70	\$103	
277	2.216	50%	1.108	7	0.158	\$445	\$277	\$106	1.58	\$151	\$266.25	\$135	
277	2.216	33%	0.731	7	0.104	\$445	\$183	\$70	3.73	-\$52	\$403.40	\$205	
120	1.920	66%	1.267	6	0.211	\$406	\$317	\$122	0.74	\$276	\$217.01	\$104	
120	1.920	50%	0.960	6	0.160	\$406	\$240	\$92	1.80	\$110	\$286.46	\$137	
120	1.920	33%	0.634	6	0.106	\$406	\$158	\$61	4.07	-\$65	\$434.03	\$207	
120	0.960	66%	0.634	3	0.211	\$290	\$158	\$61	2.16	\$51	\$339.33	\$118	
120	0.960	50%	0.480	3	0.160	\$290	\$120	\$46	3.69	-\$32	\$447.92	\$156	
120	0.960	33%	0.317	3	0.106	\$290	\$79	\$30	6.93	-\$120	\$678.66	\$237	